

Automotive Technology Group, Inc

Information Package – 2011

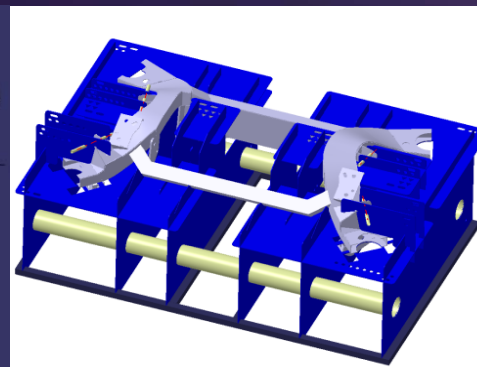

Thank you for your interest in Automotive Technology Group (ATG), a full service engineering, manufacturing and motorsport organization. Our customers receive all the benefits of a leading technical partner, including extensive process driven manufacturing experience, engineering prowess and development expertise.

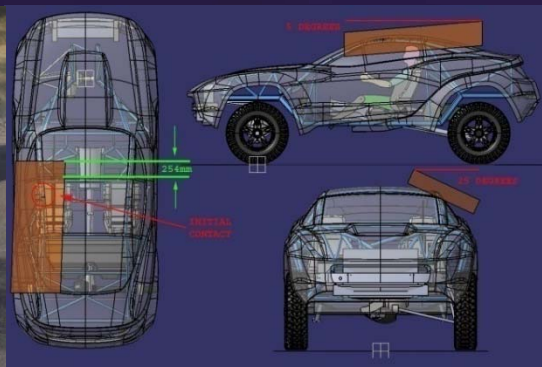

Automotive Technology Group, Inc. is a privately-held California corporation, founded in 2002, specializing in engineering, low-volume manufacturing and program management. Our team has experience executing large programs for automotive OEMs and the defense industry as well as small entrepreneurial programs where educating the customer is as important as the final product.

At ATG, we combine our practical expertise with process driven manufacturing to ensure build quality and presentation is second to none. By paying special attention to detail, we provide effective engineering solutions and OEM build quality that ensures customers' achieve maximum value for their investment.

Mission Statement

To provide products and services that increase our clients' success and build brand image through precision engineered solutions, high quality niche manufacturing and effective program management.



Company Services Overview

While our company roots are grounded in motorsports, the majority of our business is in automotive technology where we work closely with major manufacturers, suppliers and start up car companies. Here is an overview of our full spectrum of services.

Automotive Technology Group, Inc.

Automotive Technology	Manufacturing	Motorsport	Government Services
Production engineering and development	Low volume component manufacturing	Race car and component sales	R&D Engineering
Hybrid and Electric powertrain design and simulation	Composites, tooling, CNC patterns	Radical SR3 aftermarket parts	R&D prototyping and testing
FMVSS consulting, testing and document submission	Full fabrication, machining and sheet metal capabilities	Professional race engineering and track support	Engineering services
Airbag system design and integration	Wiring looms and controls	Racecar manufacturing and restoration	
Production planning and tooling	Low volume up-fitting		
Composites structures and tooling design	Consumer product development		
Simulation and analysis			
Prototype and low volume manufacturing			



Capabilities Statement

ATG is a small U.S. based research and development company specializing in fast paced engineering and development programs for commercial and military applications. Our team has extensive experience in the design, manufacture and testing of advanced vehicles for on and off the road as well as general consumer products and advanced electronics. We have hands on experience in the development and simulation of hybrid and electric vehicle systems and manufacture all systems and wiring in-house to ensure the highest quality.

Company Profile

Legal Company Name: Automotive Technology Group Inc.
Cage Code: 58E23
Duns: 125152467
Business Classification: Small Business (California certified small business certificate holder)
Primary Contact: Steven Trindade (President / CEO), Phone: 949-296-2152

Resources

Catia V5	Optimum-k Kinematic Simulation	Rapid Prototyping (SLA)	Solidworks
Motec Data Systems	CNC Milling	Cosmos FEA	Direct Soft Controls
Machining / Fabrication	Matlab / Simulink	CarSim / TruckSim	Advanced Composites
Alias Digital Surfacing	MS Project Scheduling	Electronic Controls and Wiring Looms	

NAICS Codes

541330 Engineering Services	541340 Drafting Services
541420 Industrial Design Services	541490 industrial Design Services
336111 Automobile Manufacturing	336112 Light Truck / Utility Vehicle Manufacturing
336211 Motor Vehicle Body Manufacturing	336322 Other Motor Vehicle Electrical
336330 Motor Vehicle Steering & Suspension Mfg.	336350 Motor Vehicle Seating and Interior Trim
336399 All Other Motor Vehicle Parts Manufacturing	336991 Motorcycle Parts Manufacturing
336992 Military Armored Vehicle, Tank, and Tank Component Manufacturing	
541712 Research & Development in the Physical, Engineering, and Life Sciences (except Bio-Tech)	



Automotive Technology Engineering and Development Services

Our customers rely on us to provide a wide range of technical services including:

- Complete automotive engineering, design and development
- Engineering and tooling for composite or metal manufacture
- Mechanical simulation – FEA, CFD and kinematic simulation
- Production planning and manufacturing throughput improvement/ simulation
- Component design and development
- Fabrication and component assembly
- Electrical system development and wire harness manufacture
- Dynamic performance evaluation and development
- New product engineering, tooling and development

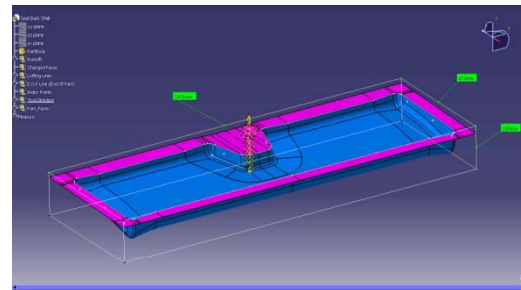
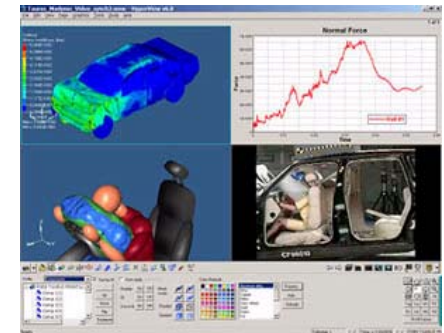
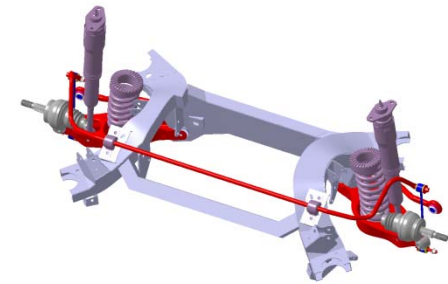

Automotive Technology Hybrid and Electric Powertrains

Our experience in Green Technologies speaks for itself: we are proud to be a part of some the leading alternative energy programs in the auto industry including:



- Chrysler Town & Country Hybrid
- Dodge 200C & Dodge EV Electric Vehicle
- Jeep Patriot and Wrangler Hybrids
- Fisker Karma – Hybrid luxury performance
- Aptera TYP-1 – Ultra efficient electric
- Ronn Motors Scorpion – Hydrogen powered supercar
- Local Motors – Clean Diesel flexible platform vehicle
- Norma M20F – E85 fuel LMP-3 Sports Prototype race car



Alternative Fuels: Applications for use with alternative fuels or conversion of existing internal combustion engines to run on alternative fuels and fuel blends.

Electric power trains: System engineering, Matlab/Simulink simulation, integration and packaging of new electric power trains as well as conversion of existing vehicles to electric drive

Hybrid power trains: Complete engineering, Matlab/Simulink simulation, integration and packaging of new hybrid power train systems.

ATG engineers, manufactures, assembles and tests all systems and subsystems providing you with a one-stop vendor for your complete program.



Automotive Technology FMVSS Consulting and Testing

Federal Motor Vehicle Safety Standards can be difficult to understand and can account for a large portion of a new vehicle's development cost and lead time. Our experienced team will guide the development of new or imported vehicles down the right path the first time eliminating the need to re-engineer and rework vehicles in order to become FMVSS compliant.

- FMVSS certification, documentation and testing
- Engineering new vehicles and components for compliance
- Integration of existing certified components
- Component sourcing, supply chain development and vendor management
- Testing oversight and coordination
- Crash testing, dynamic testing, occupant safety tests, lighting tests

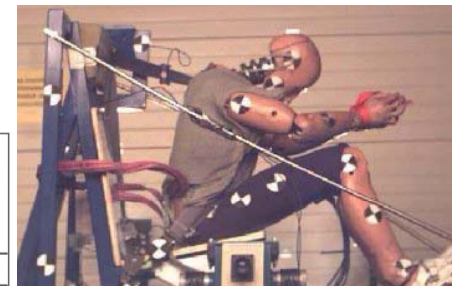
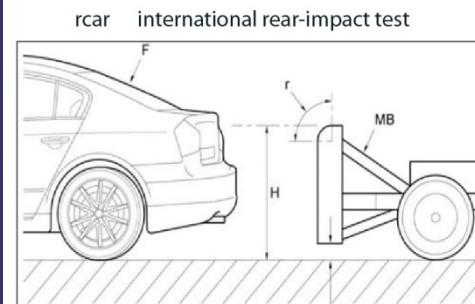
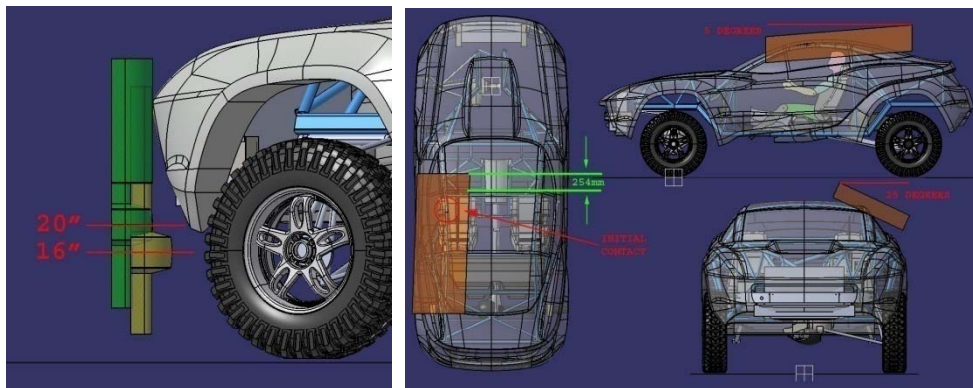

Automotive Technology Custom Engineered Airbag Systems

ATG is an approved partner of TRW and Bosch allowing us complete access to their full lines of safety systems for design and integration into your new vehicle. As the only supplier in North America providing this service, and by combining it with our automotive engineering capabilities, front and side curtain airbags can be designed into your new vehicle from the beginning ensuring FMVSS compliance and safety.

Benefits include:

- Low cost: by including the airbag engineering in the body and structure engineering phase we can design an integrated system using off the shelf TRW tooled components. TRW will manufacture specific airbags and perform component testing to ensure positive results during final phase crash testing.
- Total cost of program approx \$850,000 depending on vehicle
- Access to original CAD data for all occupant safety system components
- Complete occupant protection system including front and side curtain airbags, Air bag control modules, crush zone sensors, looms, seat belts, retractors and buckle assemblies



Manufacturing Low Volume Manufacturing and Assembly

ATG manufactures everything from prototype components and assemblies to production tooling and saleable components. In addition inspection, assembly and packaging is done onsite making ATG your on stop partner.

We currently provide fabricated, machined and sheet metal assemblies to nearly a dozen individual companies who brand the products we manufacture and sell them as their own. These parts are installed on a wide variety of products around the country.

Components are typically provided complete after powder coating or finishing to customer specifications. Packaging and drop shipping services can be provided.

To ensure quality production, processes are developed for all programs that manage material, work flow and quality.



Manufacturing Composite Components, Tooling and Patterns

Modern vehicles rely on modern technologies and materials. Motorsports led the auto industry into advanced composites and we are uniquely positioned to provide a large base of knowledge in all facets of the use composite structures as a result of our extensive motorsport experience.

Pattern Making: CNC Machined full size patterns made of high density foam or tooling board suitable for all types of composite tooling.

Tooling: Composite tools for wet layup fiberglass or precision tools for vacuum bagged and autoclaved carbon fiber and Kevlar

Components: Low volume manufacturing of composite components for car bodies, automotive interiors, internal ducting, and aerospace applications. All types of laminates and materials including, wet layup, pre-preg carbon fiber, vacuum bagging and autoclave. Light weight and low costs components can also be manufactured using a resin infusion scrimp process. Various cores types can be molded in including wood, closed cell foam, nomex honeycomb and aluminum honeycomb.



Manufacturing Electrical Wiring and Control Systems

As the largest supplier of prototype and pre-production vehicle electrical systems in the United States we have the experience to ensure the success of your program. We work with clients to determine their needs ahead of time and carefully engineer the complete system. Detailed manufacturing ensures a quality product and total reliability. To date we have achieved 100% reliability in all of the vehicle systems we have manufactured.

Vehicle Looms: Complete engineered and manufactured systems to control all aspects of the vehicle including remote actuation of lighting systems and advanced hydraulic or electric powered kinematics systems. Complete wiring harnesses for pre-production cars in low volume.

Consumer Products: We supply several manufactures with electrical assemblies that we have designed and now manufacture for re-branding and consumer sales.

Low Volume Manufacturing: Low volume manufacturing of electrical looms for race cars, motorcycles and low volume special vehicles. Systems include engine management, data acquisition and telemetry.

Industrial Controls: PLC based systems for process control, data collection and analysis. Full service system design, component specification, PLC ladder programming and implementation.



Motorsports Racecar Engineering and Team Services

Our team has managed or provided race team services to multiple motor sport programs including such organizations as Bobby Archer Motor Sports, The Champ Car Series, Norma North America, Porsche Motorsports North America, Prodrive, Radical Racecars, Saleen Performance, Truspeed Motorsports and Tool Racing.

We provide engineering, management and program planning for professional programs or existing teams moving up to a new series. On track race engineering, strategy and data acquisition can be provided in addition to private engineering development and testing.

Specific engineering development programs can be carried out including component and assembly engineering, FEA, vehicle dynamics, model making and aerodynamic development, performance simulation, non-destructive testing and failure analysis.

Race car preparation or fleet maintenance is performed at our facility to ensure your race cars are ready for the next event. We maintain all the resources of a professional motorsport organization including transporters, timing stands, pit carts, pit awnings, tire carts, motor scooters, and setup equipment, including digital scales and alignment tools.

- 2011 SCCA World Challenge Champions (Engineered by ATG)



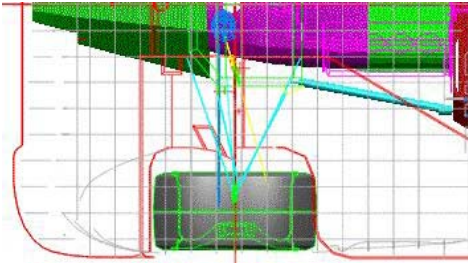

Engineering Tools

Catia V5 R18
Solidworks 2009
Digitizing & Laser scanning
FEA analysis
Extensive automotive OEM part library

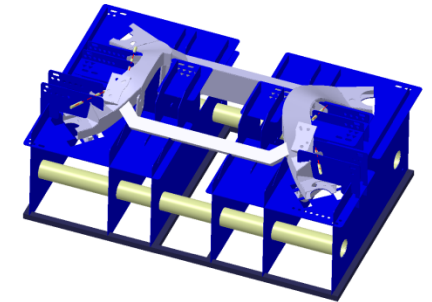

Vehicle Simulation Software

Win-geo V3 & Optimum K Suspension Geometry
Matlab / Simulink
Proprietary Vehicle Dynamic Software
Motec, Pi, DTA Data & Engine Management

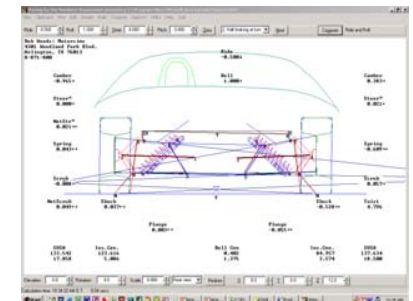

Manufacturing

Rapid Prototyping and model finishing
CNC and manual machining
Component and assembly manufacturing
Tooling and assembly for composite structures
Proprietary project management software
Prototyping capability for one off projects
Low volume tooling and manufacture of special projects
Process driven manufacturing
Experienced supply chain management



Please enjoy the following sampling of projects where we have contributed to the overall success of the program.



Chrysler's family of EV's
Pre-production engineering and manufacture of EV & Hybrid powertrain systems for development vehicles



Aptera TYP-1
Production engineering of front sub-frame & suspension, FEA, casting development, component sourcing, NVH and dynamic simulations



Jeep Trail Hawk
Complete electrical system manufacture & install. Basic system with PLC based electronic transmission control



Local Motors Rally Fighter
Production body engineering, clean diesel powertrain development, airbag development and FMVSS certification



Ford Airstream
Complete electrical system manufacture & install. PLC based with remote control of kinematics and lighting sequences



Piper Piperjet
Complete electrical system manufacture & install. Interior & exterior lighting system with show power and air conditioning



Mazda Kabura
Complete electrical system manufacture & install. PLC based with remote control of kinematics and lighting sequences



Dodge Hornet
Complete electrical system manufacture & install of basic system.



Fisker Karma

Complete electrical system manufacture and installation. manufactured prototype parts, finish modeled and installed Interior/exterior details. Engineered two versions of mule chassis



Jeep Renegade

Engineered aluminum chassis and suspension as well as packaging electric power train and batteries.



Toyota ABAT

Carbon fiber body Engineering & tooling design. Kinematic design of shut faces including suicide doors, Mid-gate, tail-gate, & bed storage facilities

TOP SECRET

Volvo Concept Center

Engineered and manufactured advanced active safety system. We would love to tell you more but it is top secret.



Chrysler Town & Country

Engineering integration and design of hybrid drive system. Manufactured all new chassis, sub-frame, and suspension for development vehicle



Chrysler 200C

Engineering integration and design of hybrid drive system. Manufactured all new chassis, sub-frame, suspension and floor sheet metal for full running development vehicle



Truspeed Motorsports

Provide engineering services to 3 car Professional World Challenge Porsche race team including, race engineering, test planning and execution and vehicle development



Tricom Research

Engineered multiple remote surveillance systems for the US military now in action around the world



Automotive Technology Group is fully committed to achieving all of our customers' objectives by working with you to develop a program that addresses your specific needs, including:

- **Engineering and development** for all manner of programs including OEM, aftermarket, product development, manufacturing, tooling, and motorsport
- **FMVSS certification** specialists and the only engineering company in the U.S. with an OEM airbag manufacturing partner allowing us to provide complete airbag integration, development and testing.
- **Low-volume manufacture** of consumer products including; up-fitted or new complete automobiles, consumer electronics, defense and military products.
- **Complete race car preparation**, arrive and drive programs, motorsport management, race team execution, and sponsor hospitality

We invite you to visit us with your engineering or manufacturing challenge so that we may provide you with a well engineered, quality solution.

Contact:	Steve Trindade
Phone:	949-296-2152
Cell:	817-875-5268
E-Mail:	Strindade@AutomotiveTechnologyGroup.com
Address:	17173-B Gillette Ave Irvine, CA 92614
Web:	www.AutomotiveTechnologyGroup.com

